

PERFORMANCE IMPROVEMENT: COMBUSTION AND HEAT TRANSFER OPTIMIZATION

Joseph R. Comparato
Fuel Tech, Inc.
512 Kingsland Dr. • Batavia, Illinois

Presented at the ACC PRB Coal Use Conference, St. Louis, MO, July 2007

Modern power plants are complex systems with many challenges and opportunities for performance improvement. The clean use of coal requires fine tuning and coordinated operation of many extensive subsystems. Today's competitive pressures in electric power markets intensify these challenges. Each operator needs to harvest every opportunity to meet demand at the lowest possible production cost. Added to this is the global concern with climate change and carbon dioxide emissions. Long past are the days of looking at an electric power plant as a major capital investment to be run in a routine and passive mode. Continual performance improvement is the order of the day.

Opportunities for improvement extend from coal pile to stack and from condensate pump to condenser. Combustion and heat transfer are the most evident processes. Fuel Tech[®] is known for its chemical treatment programs. NOxOUT[®] products provide highly cost effective processes for controlling air pollution emissions. FuelChem[®] products help manage ash deposition, acid plume, and corrosion. These products are very much intertwined with the combustion and heat transfer processes. They rely on advanced computational modeling and

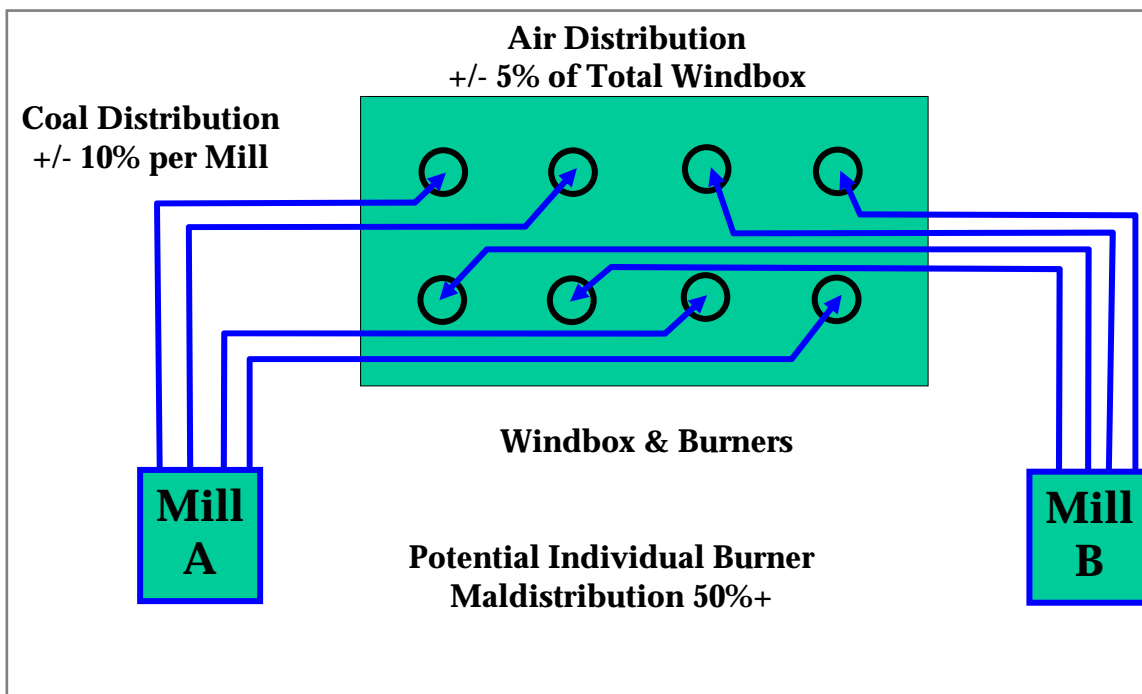

Figure 1 Windbox and Mill Variation Can Hurt Performance

visualization tools for problem diagnosis and intervention. The technology also provides a framework for services to discover opportunities and identify problem solutions.

The burner front is a good place to start. It may be difficult to define with boilers that are front and rear fired, down-fired, turbo-fired, T-fired, stoker-fired, or fluidized beds. However, the tradition is somewhat honored in that this is where the boiler nameplate is usually hung. What happens here is strongly affected by actions often thousands of miles away where the coal is mined. Fuel selection and blending should be aggressively managed. But, this is a balance between trading favorable combustion properties against cost. A well tuned firing system will be more tolerant of fuel variation. Chemical treatment to control ash properties can broaden the range of acceptable variation in coal ash properties.

A multi-burner pulverized coal firing system provides perhaps the greatest potential for things to go wrong. Generally, a number of round burners are supplied with air from a common windbox. The fuel is supplied to the burner from air swept mills that dry and pulverize the coal. Usually a minimum of four burners are fed from each mill. The drying air transports the fuel through a

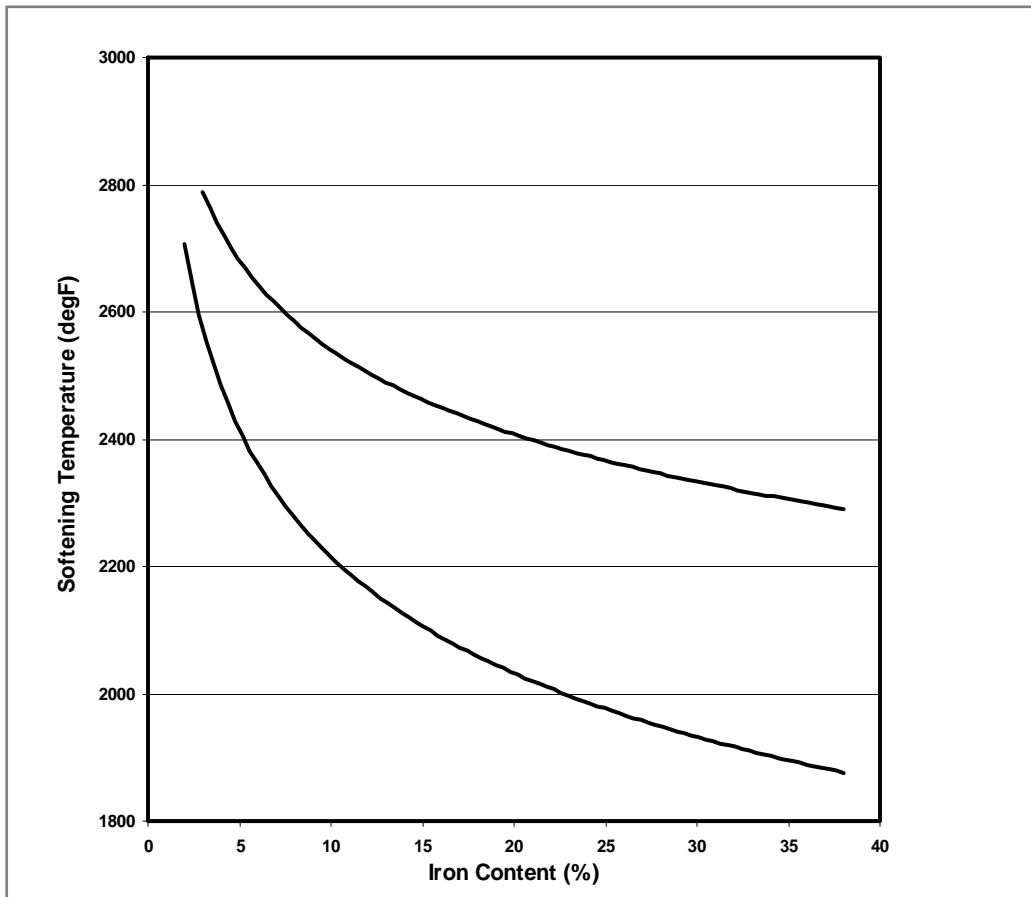

Figure 2 Effect of Reducing Conditions on Ash Softening Temperature

splitter and conveys the coal to the burners. The windbox must be carefully designed to provide uniform distribution to the burner registers. Dual register burners control NOx by staging the combustion with secondary and tertiary air dampers.

Good windbox design would assure that the distribution to each burner is within 5% of the total flow. Good mill distribution would assure that the fuel split is within 10% of the mill flow. However, this could easily result in an individual burner having a greater than 50% variation from design (see Figure 1). Deeply staged combustion systems will have a design of less than 80% of stoichiometric air flow at the burner. Any maldistribution can result in local reducing conditions that will cause slagging and corrosion.

Ash can form tenacious deposits in regions where the gas temperature is greater than the initial softening temperature of the ash. Figure 2 shows the general trend of differences between oxidizing and reducing conditions. High sulfur fuels with high iron content can be very troublesome. Chemical treatment using FuelChem TIFI[®] changes the structure of the ash to make it easier to remove.

Burner tuning is a means for getting the right air to fuel ratio at each burner. The installation of baffles and vanes may be required to fix a poor distribution inherent in the design. Adjustment of individual dampers at each burner is a painstaking art. A common design is eight rows of six burners (four row each front and back), or 48 burners. There are large units with 88 burners. An adjustment to one burner affects the flow to other burners. So, this is not an easy task to do by trial and error. With TIFI a wide range of lower grade fuels can be used with a well tuned burner system, or a burner system with problems can run well with the design fuel.

APPROACHES TO PERFORMANCE IMPROVEMENT

After many decades, some would say centuries, engineers now use high performance computing routinely to design products. For example, the Boeing 777 gained notoriety as a product designed from nose to tail with computers. More routinely, process simulators and computational fluid dynamics programs are utilized to design and refine burners, boilers, back-ends, and balance of plant.

The next step in this evolution is to put these tools in the hands of the plant performance engineer to continually improve efficiency, availability, output, and overall economics while minimizing environmental impact. Electric power utility power plants now commonly have sophisticated digital control systems. These typically include data acquisition systems with large capacity archives and programmable reporting. What's often missing, however, is enough time in the day to look at the numbers and continuity among the performance engineers who would evaluate results.

It is not unusual that performance improvement is treated as a "project" to be investigated intensely. CFD models may be developed to diagnose problems and identify solutions to problems. Efficiency simulations can be run to quantify benefits. Once the objectives are achieved there is a tendency to move on to another project. Experienced engineers will move on as well to advancements won from recognition of jobs well done. Quality programs that emphasize continual improvement tend to generate many projects, with many meetings, starts, and stops. Methods that provide continuous, intensive assessment of performance would greatly enhance and accelerate these efforts.

Virtual reality techniques are now ready to provide an environment for continual performance improvement. Once too expensive for anything less than a major project, software and hardware

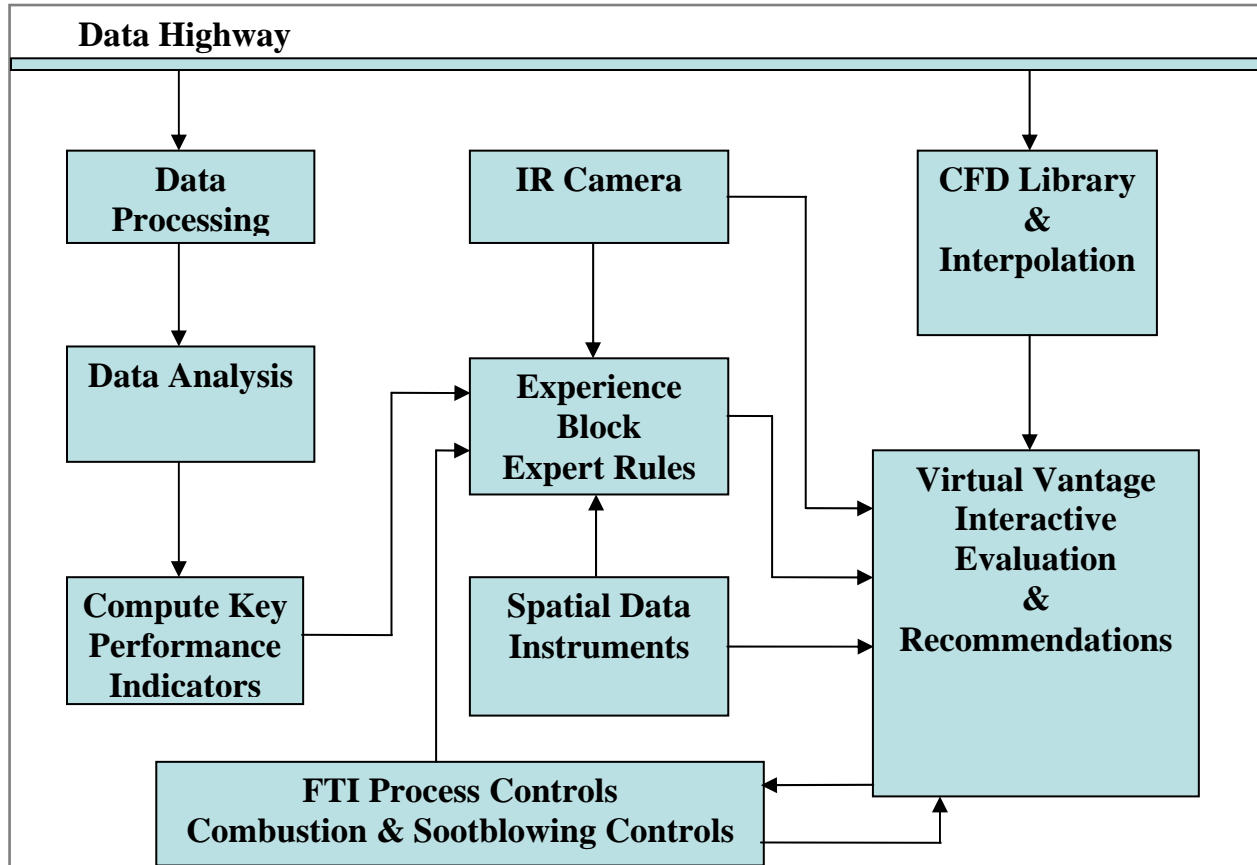

Figure 3 "Knowledge" Flow Diagram

cost are a fraction of that required just a few years ago. Intuitive interfaces essentially eliminate the need to “relearn” the software each time it’s used. The virtual environment is well developed for working with simulations. With the next step “real world” data are displayed and compared with simulations in real time. Differences provide useful cues for ad-hoc evaluation. Other systems, such as advanced instrumentation and artificial intelligent agents, enrich what’s known and what can be done about any situation.

Figure 3 is an example of the information flow that can be available to the plant engineers and operators. The system can be built in pieces and refined over time. It can be implemented initially as a manual process and automated at a later time. Data are taken off the data highway. Various methods can be used for this. A custom program can be written to read, average, and capture data. Or, a variety of commercial add-on programs or “historians” built into the DCS will do the job. The data are processed into information to identify key performance indicators important to identify the behavior of the system. The experience gained by observing behavior can be in the form of performance charts that are routinely reviewed by the performance engineer. Or, ultimately, an expert system can be developed with expert rules that say “I’ve seen

this before and this is how to handle the problem”. Information can be brought in from other sources, such as infrared camera imaging and 3D temperature and species data. At the core is a virtual reality interface where information is displayed to provide knowledge for making decisions. A library of simulations, such as CFD solutions for an array of conditions, provides the information on how things “should be” based on the current conditions as found by inputs from the data highway. The system can interact with other optimization programs such as intelligent combustion and sootblowing programs, which often go astray because no one is looking at them.

The task of scoping the data sources may at first seem daunting. But, this isn’t really a big task. Data sources in an electric utility plant can easily exceed 10,000 tags. For performance evaluation the number needed to compute heat absorptions and efficiencies is typically around

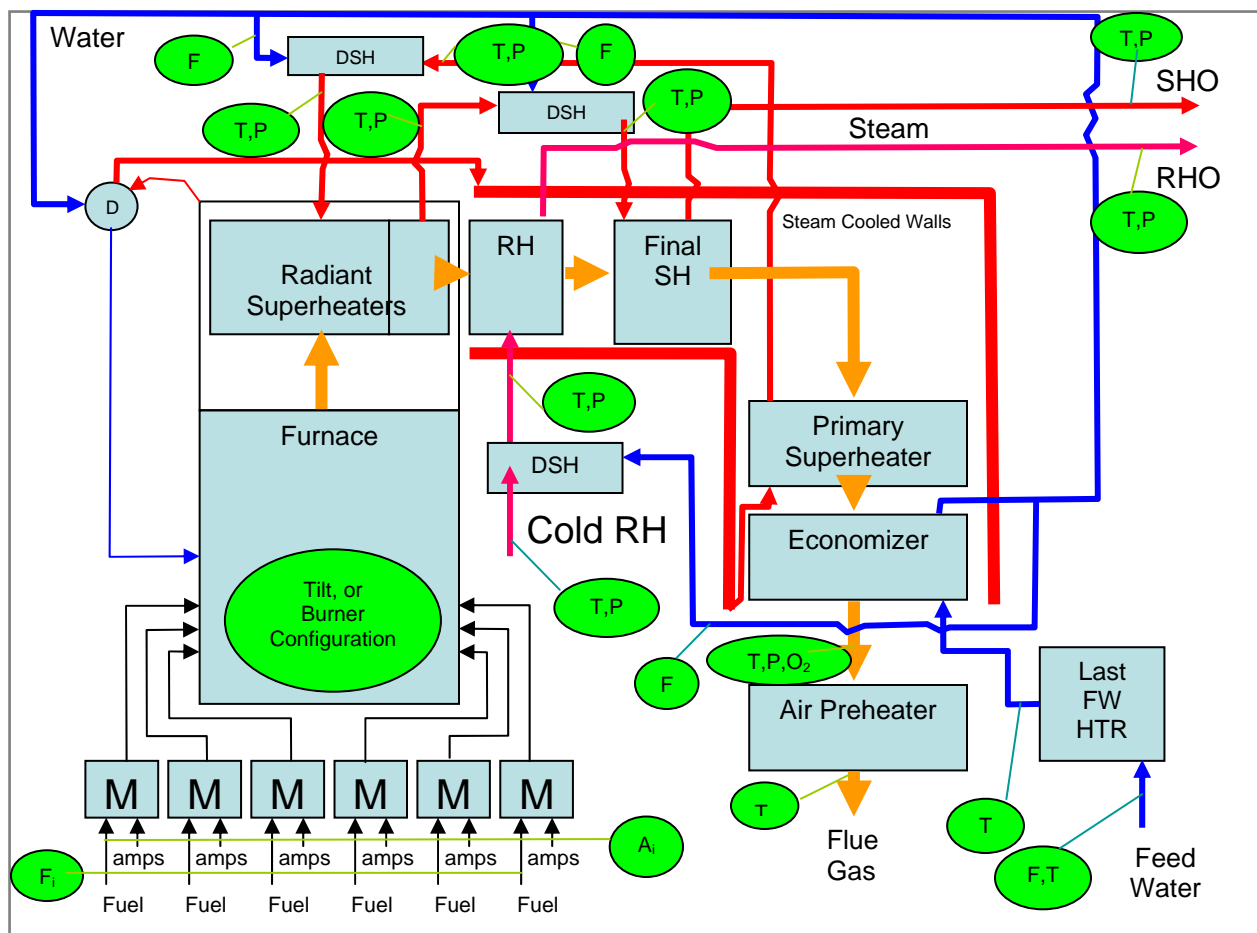

Figure 4 Typical Instrument Tags in a Subcritical Boiler Island

150 items. Editing tools make the process of selecting the appropriate tags fairly simple. Sorting and filtering edit tools are used to select the list of pertinent tag identifications.

The typical tags for a generic sub-critical steam generator are shown in the diagram in figure 4. Furnace wall heat absorption predominantly goes to raising steam to saturation, and thus can be

High performance computing is no longer a futuristic tool. It is now effective and affordable. Its evolution needs to be guided by users who place the technology into everyday practice. The economic and environmental opportunities are very large. Practical problem solving may lead to interventions such as burner tuning or other modifications that provide large payback in an increasingly competitive industry.

INTERVENTION OPPORTUNITIES

Efficiency improvements have economic and environmental benefits. A direct way to reduce CO₂ emissions and its impact on greenhouse gas emissions is to reduce the amount of fuel burned. High attenuation flows to control reheat temperature will reduce turbine cycle efficiency by short-circuiting the regenerative superheat stage. Cleaning the various heat transfer sections of the boiler can provide a reduction in reheat spray requirements. Combustion problems resulting in carbon loss are often due to fuel imbalances. The resolution of the combination of several problems has shown several percent improvement in efficiency. Generally, steps that reduce the variability of plant operation will increase efficiency, availability, and utilization of capital.

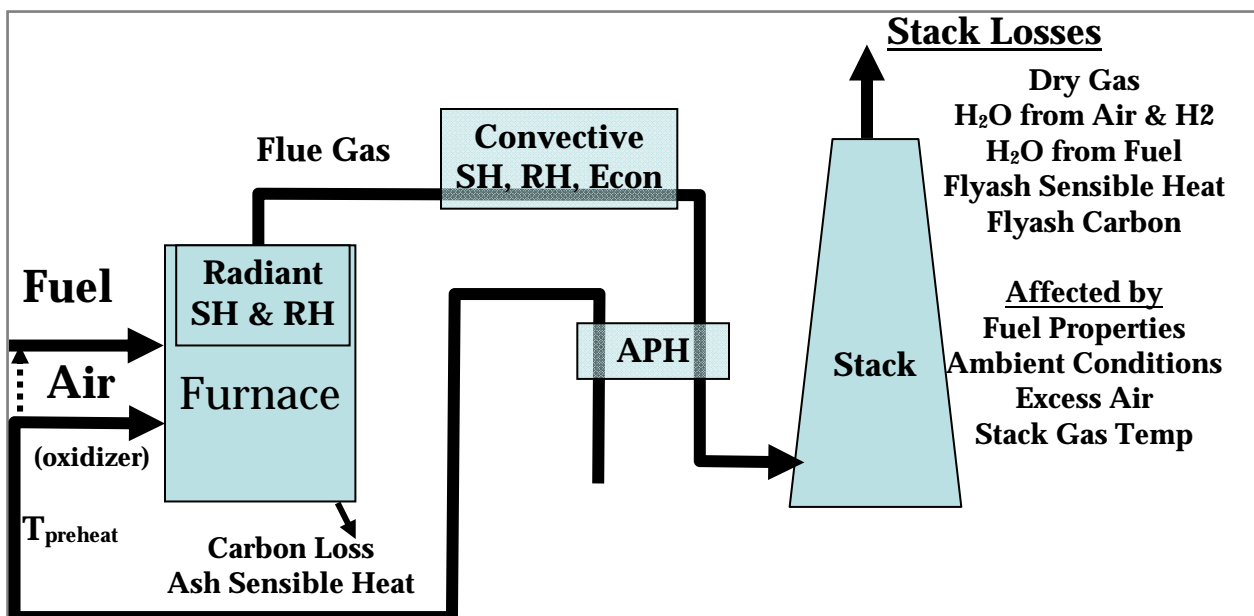

Figure 6 Boiler Efficiency Losses

Boiler efficiency losses are predominantly the energy that leaves the stack and unburned combustible. Steps that allow a reduction in temperature of the flue gas leaving the stack have a large effect on boiler efficiency. As a rule of thumb, a 40°F reduction in stack temperature provides a 1% improvement in boiler efficiency. Chemical injection to capture SO₃ may allow additional heat extraction to lower the stack gas temperature. Or, in the winter time, steam coil air heaters could potentially be turned off or reduced in steam flow.

Reduction in excess air is also a strong factor in improving boiler efficiency. Since air is 20.9% oxygen and 79.1% nitrogen (dry basis) it is the nitrogen that comes with the air that carries the bulk of the loss. TIFI has been used to control slagging problems so that excess air can be reduced. In one case the operating O₂ has been reduced from 3.2% to 2.6% providing a 1% gain in boiler efficiency. It also reduced NO_x emissions by 12%, producing revenue from NO_x credits.

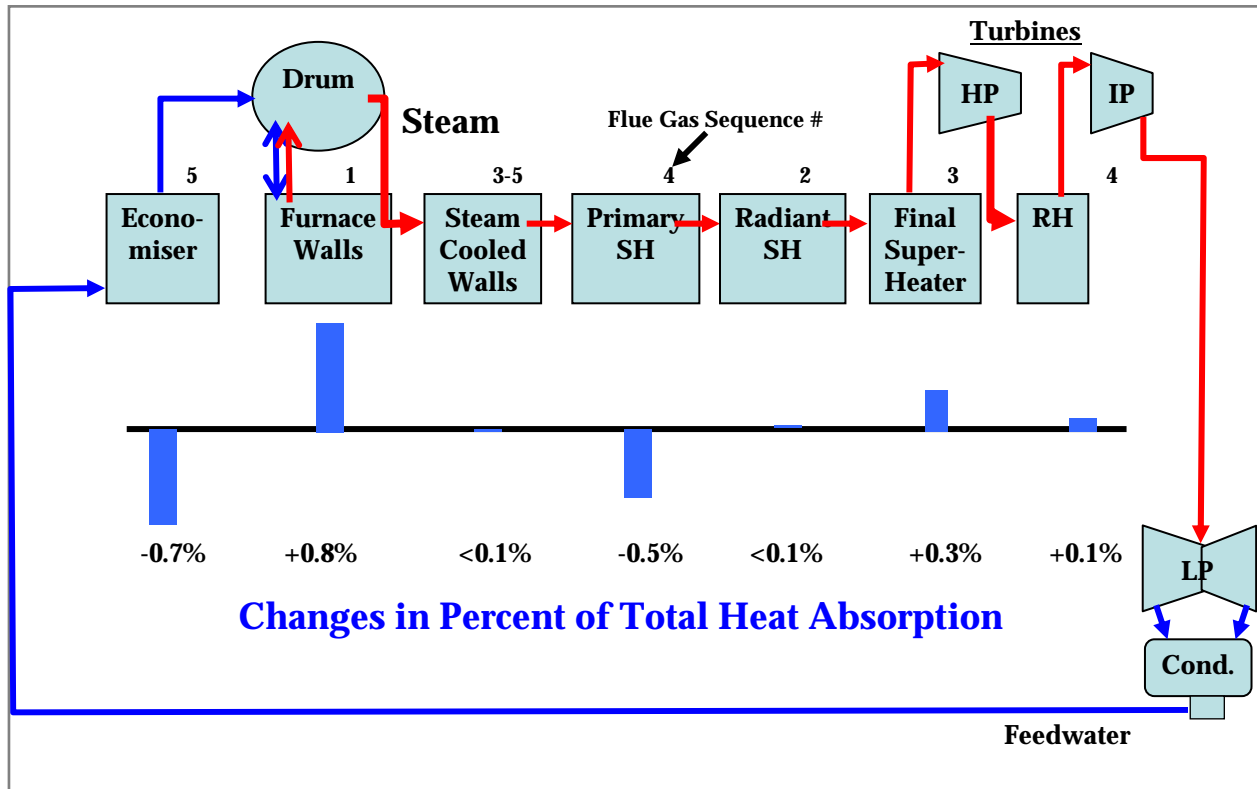

Figure 7 Redistribution of Heat Absorptions

REDISTRIBUTING HEAT ABSORPTIONS

Burner modifications and ash treatment provide the means for shifting the absorption profile in a unit. Deep staging of the burner tends to lower peak furnace temperatures. Since radiation is proportional to the fourth power of temperature, furnace radiation can be dramatically reduced. The combustion is “stretched out” resulting in lower furnace absorption and higher furnace exit gas temperature. On the other hand, low NO_x burners often run at reduced excess air. This raises the adiabatic combustion temperature which can compensate for the heat loss gain.

In another case the client was having problems exceeding metal temperatures at the primary superheater outlet. This was largely due to furnace fouling. TIFI treatment provided a 0.8% of increase in furnace wall absorption as a percent of total boiler absorption. While the radiant superheater became cleaner, which would increase absorption, the cooler furnace offset this. The gas temperature entering the primary superheater was reduced and helped lower the metal temperature. The final superheater and reheater circuits were cleaner and absorbed more heat.

The economizer then was left with less work to do. While the economizer absorption was reduced, the temperature of the gasses leaving the economizer, instead of increasing, was reduced.

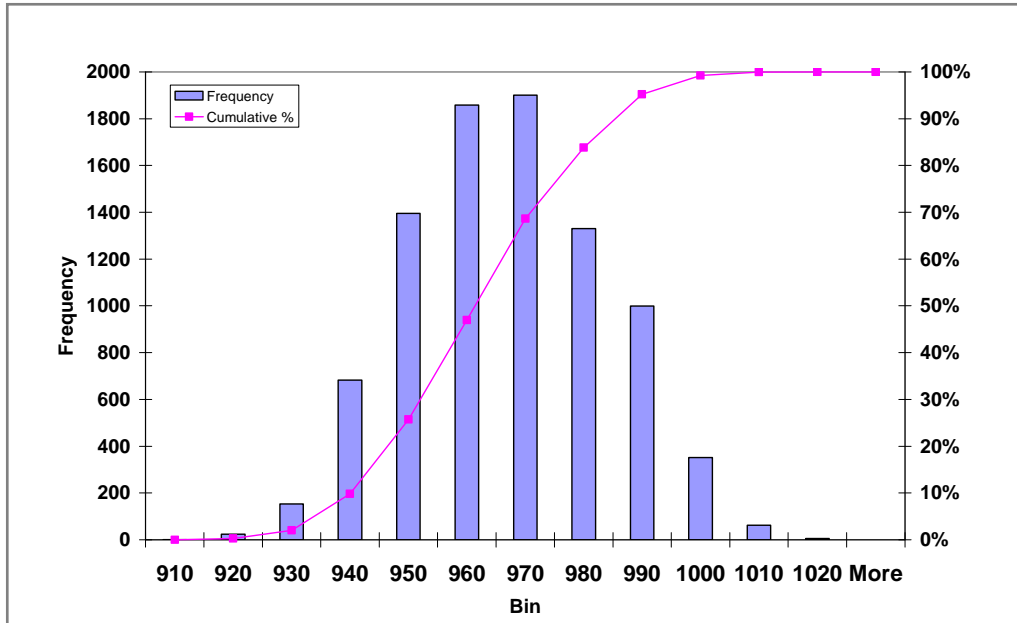

Figure 8 Superheater Outlet Temperatures Before Treatment

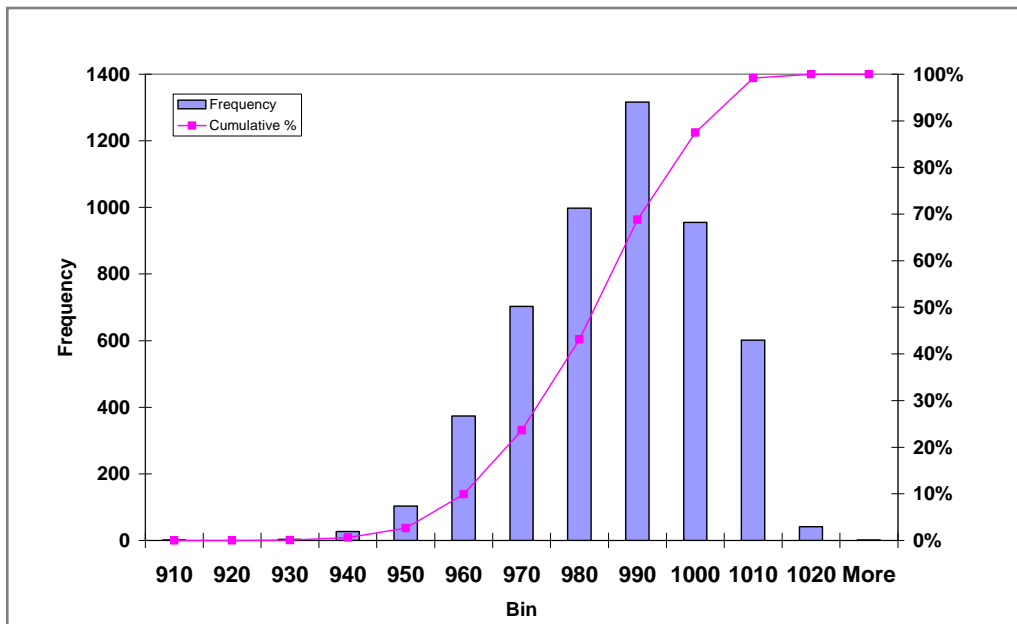

Figure 9 Superheater Outlet Temperatures After Treatment

The process can be tailored in the opposite direction. With a different application the radiant superheater was fouled heavily on PRB coal. Total steam temperatures were about 35°F below design. TIFI was targeted at the radiant superheater. Superheat recovered substantially. The

shift in superheater frequency for collected data bins for temperature can be seen in Figures 8 & 9. In addition to the shift to a higher level, the deviation narrowed and showed bias toward the target.

IMPACT ON TURBINE EFFICIENCY

Superheater and reheater steam temperatures have significant impact on the turbine performance and life. A loss of temperature reduces the output of the turbine. Swings in temperature cause cycle fatigue in the turbine chest and will reduce the remaining life assessment (RLA) for the unit.

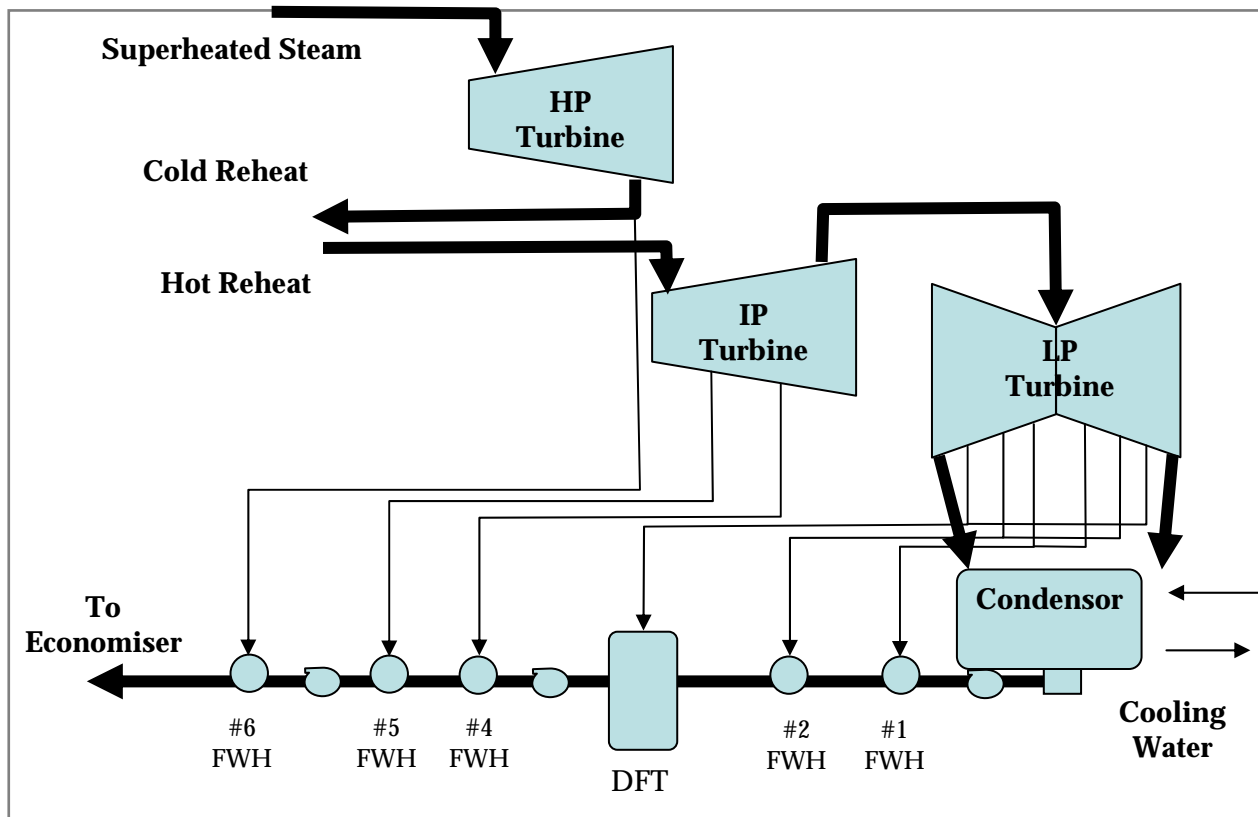

Figure 10 Turbine Cycle -- Generic Subcritical System with Six Feedwater Heaters

Figure 10 presents a simplified diagram of a typical subcritical turbine cycle. High pressure superheated steam produced by the boiler is expanded in the high pressure (HP) turbine. The cold steam is then sent back to the boiler for reheating. The hot reheat is expanded in the intermediate pressure (IP) turbine. At various stages steam is extracted from the IP turbine. The discharge from the IP turbine is further expanded in the low pressure (LP) turbine. Figure 11 is a thermodynamic cycle diagram for the turbine process. The chart is a TS diagram, or temperature (T)—entropy(S) diagram. The blue portion of the curve is saturated liquid water, the red curve is saturated vapor or steam, and in between is a mixture. The curve for a supercritical cycle would lie above this curve, as at supercritical pressures there is no phase change.

There are two basic reasons for the complex circuit with the various looping about. First, if the steam were expanded in one shot, it would form water droplets too soon. In the turbine, the steam is isentropically expanded, i.e. expanded with constant entropy. Thus, the expansions are, roughly, straight lines downward. The superheated steam would drop below the red curve and form a mixture of vapor and water. This is bad for the turbine and ends the process before the most work can be gotten from the steam—which leads to the second reason. By sending the steam back for reheating, more work can be done before the latent heat is discarded in the condenser. The work produced in the turbine is the line integral of temperature and differential entropy, which forms the area within the cycle path. The extraction flows are similar to the reheat and multiply the flow through the superheater and reheater circuits. This flow is more than 50% greater than the final condensate flow.

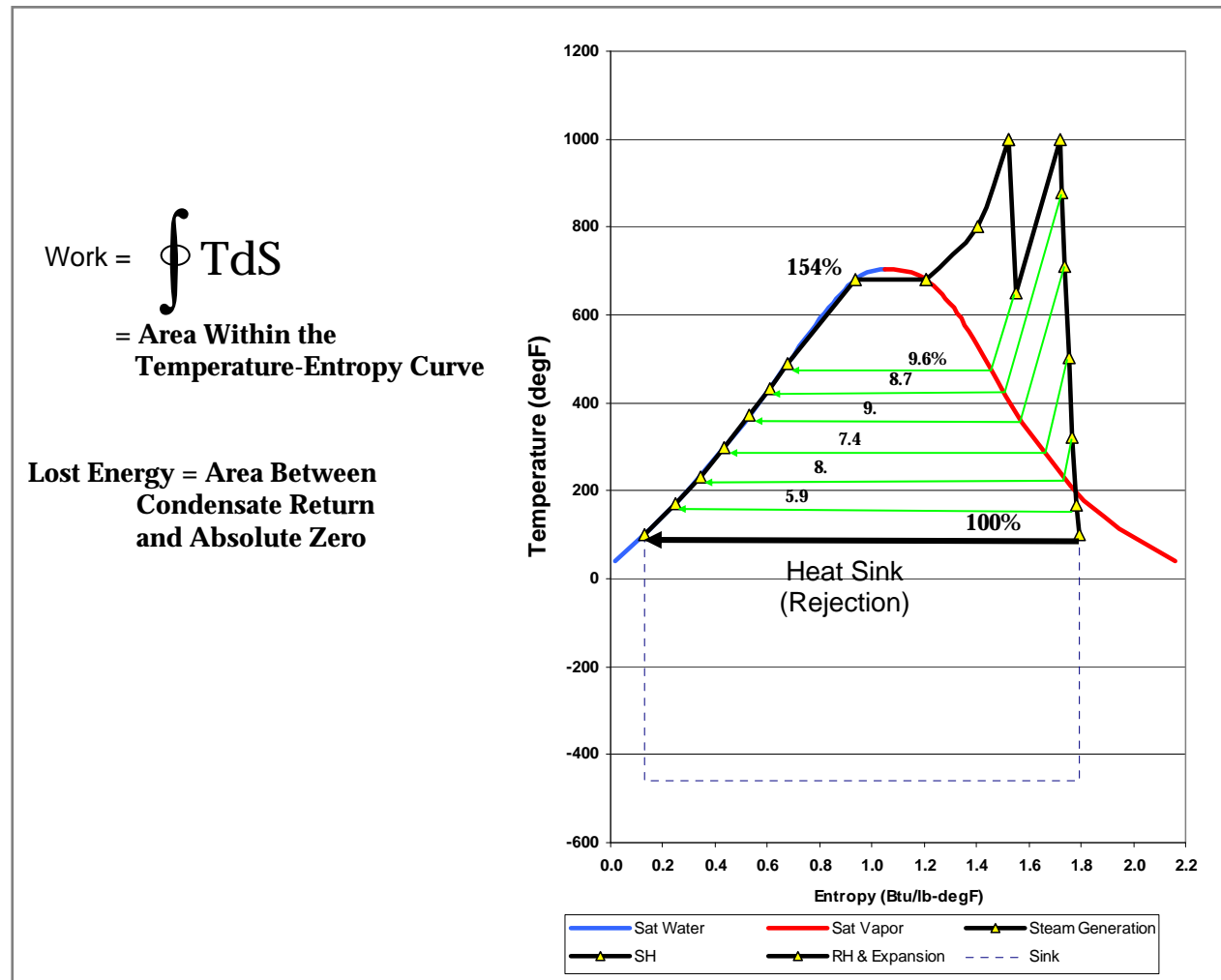

Figure 11 Temperature-Entropy Diagram Determines Turbine Efficiency

Interventions to minimize attemperator spray flows are desirable, even though it keeps temperatures on design. The water for desuperheating is normally taken from the economizer outlet header. This is low entropy water which has a small negative effect on the superheat cycle. Spraying the reheater is a larger negative impact because the spray water completely bypasses the superheat portion of the cycle.

Fuel Tech's TIFI process had a positive impact on reducing reheater spray at Georgia Power's Scherer #3 unit. The results were reported at the 2006 PRB user's group meeting¹. In this case the 880MW divided furnace (without division wall) T-fired unit experienced a significant reduction in spray flow as shown in Figure 11. The unit, as reported, also was able to reduce, and has since eliminated, load sheds to control slag accumulation and has recovered full load.

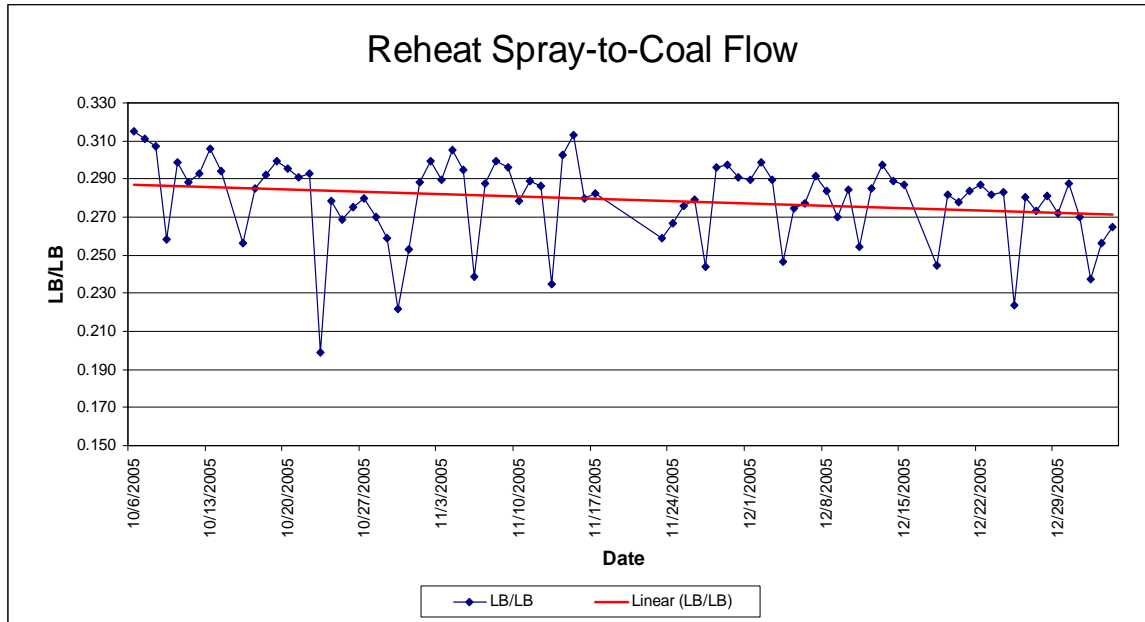

Figure 12 Reheat Spray Flow Was Reduced at Scherer #3

Improvements in plant efficiency extend well beyond the economics of fuel use and production output. Pollutant emissions such as SO₂ and NO_x are reduced in proportion to reductions in heat rate. For a typical coal fired unit, roughly one ton of CO₂ is released with every megawatt-hour produced. With mounting emphasis on climate change efficiency improvements are a productive way to reduce greenhouse gas emissions.

SUMMARY

Today's electric utility power plant operators and engineers face daunting challenges in a very competitive economic market and with looming environmental hurdles. A problem solving approach is required that uses every practical technique for continual performance improvement. Combustion and heat transfer systems are complex and very extensive. Advance computing and an active knowledge system can help identify opportunities. Various methods for optimization such as burner tuning, operational refinements, and chemical treatment programs are available to meet these challenges.

Reference:

1. Comparato, J. R., Ringel, K. L., Wilson, C., Interactive Control of Ash Deposition in Power Boilers, presented at the PRB User's Group Meeting, Electric Power Conference, May 2006, Atlanta Georgia.